



Planning Electrical Systems

for Dairy Expansions



Introduction	3
Determine Electrical Needs–Service Size	4
Select Service Location	4
Service Options–	
Evaluate and Choose Type of Service	5
Single or Three Phase Power	5
Overhead or Underground Service	6
Standby Generation	7
Temporary Service	7
Rate Options	7
Protection for Sophisticated Electronic Equipment	7
Site Considerations	8
Proper Grounding	8
Safety	9
Energy Efficiency and Conservation	9
Figures	
Farm Installation of Central Electrical Distribution	4
Single and Three Phase Service	5
Padmount Transformer for Underground Service	6
Temporary Service	7
Electrical Planning Decisions	10
Mission Statement	11

Planning Electrical Systems For Dairy Expansions

What to consider when planning a new dairy facility

If you are considering a new or expanded dairy, it is not too early to begin planning the electrical system. It is crucial to include the electrical system early in the planning process, as it may contribute significantly to the cost and design details of your expanded facility. Careful planning and design will ensure the job is done right the first time and will help avoid upgrade costs in the future.

Your existing electrical system may not be sufficient for the potentially larger motors and electrical loads of your expanded operation. You will need a detailed plan for a new or updated electrical system. There are many things to consider when developing this plan—**most importantly, safety and reliability.**

The first step is to assemble an “electrical planning team” that includes you, equipment suppliers, a qualified electrician, and a representative from your power supplier. This team will work together to identify the facility’s electrical needs and make decisions regarding

system design. Certain decisions will also require input from the general building contractor and subcontractors.

It is extremely important that you hire a qualified electrician, one with experience in agricultural wiring who will follow the National Electrical Code (NEC) as well as local codes. Make sure your electrician has been certified or licensed by the state and that the work is inspected. You may need to contact your state electrical inspector to have any electrical work inspected.

This booklet will help you understand the relationship between the electrical system and total facility design. It outlines many aspects of planning a new or updated electrical system, who needs to be involved, and what questions you should ask them. For more detailed information on agricultural wiring installation and equipment selection, consult the publications listed on page 10. For a checklist of Electrical Planning Decision, see page 10.



CALCULATE SERVICE SIZE

The electrical planning team will decide the minimum electrical requirements for your dairy. The electrical system, at minimum, must have enough capacity (amperage) to service the planned electrical loads. The best way to determine service capacity is to work with your equipment suppliers and utility or electrician to conduct an accurate inventory of all existing and planned electrical loads. The results of this inventory will only be as accurate as your ability to list all electrical equipment in the new facility.

The load survey will help your utility and electrician provide you with the appropriate service. The load survey should consist of the following information:

1. Total horsepower or nameplate wattage of all electrical equipment*
 - u lighting
 - u milk cooling system
 - u vacuum pump
 - u water heating
 - u ventilation fans
 - u space heating
 - u heated waterers
 - u feed handling
 - u manure handling
 - u air compressors
 - u other loads

*If two loads **never** run simultaneously (i.e., the milk truck pump and the bulk milk tank cleaner), use only the larger load in your calculation.

2. Size of the largest motor and how often it will be started
3. Equipment which will run simultaneously (even if only rarely)

Anticipate future expansion! Add capacity for future cooling, feeding systems, ventilation, manure handling, and other electrical needs. Inadequately sized systems can result in overloaded circuits and fire hazards.

Once the amount of electrical load and how it will be used has been determined, you should meet with your utility representative to discuss service location, type of

service (three phase or single phase), service size, and service equipment.

SELECT SERVICE LOCATION

Talk to your electrician and utility representative in the beginning of the planning process about the most appropriate locations for building service entrance panels. Minimizing the distance from the utility transformer to the service entrance panels will minimize voltage drop (a reduction in voltage due to resistance in the lines), lower the risk of stray voltage, and minimize cost. Transformers are used to “step down” the high-voltage from utility electric lines to a lower

Farm Installation of Central Electrical Distribution

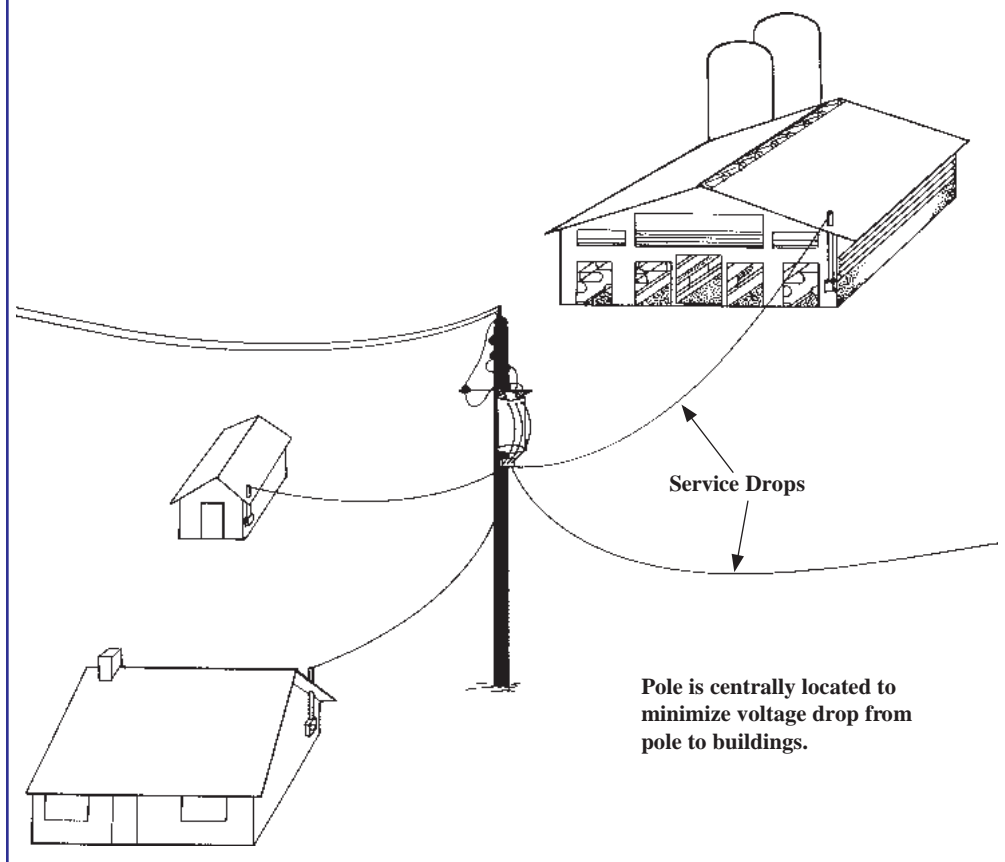

voltage that is usable at your farm or home. Transformer location will depend on the size of your service, electric codes that dictate minimum distances between transformers and doors, windows, or flammable building materials, and whether overhead or underground service is provided. Check with your power supplier to obtain all required clearances.

EVALUATE AND CHOOSE TYPE OF SERVICE

Single or Three Phase Power

Three phase electric service may be the best method for serving large motors on your dairy and may lower the risk of stray voltage. Large three phase motors can be more efficient, smaller and

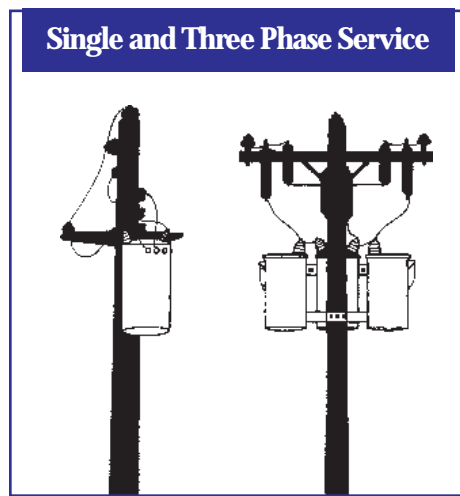

lighter, more reliable, and less expensive than single phase motors. However, three phase power is not available in many rural areas.

DETERMINE NEED FOR THREE PHASE POWER

Three phase power should be considered if:

- u there will be an electrical load of 400 amps or more, or
- u if motors of 10 HP* or greater will be used.

**Ten HP is a guideline—your utility representative can tell you the maximum motor size that a single phase power system can handle.*

DETERMINE AVAILABILITY OF THREE PHASE POWER:

- u Three phase power is not available in many rural areas
- u Ask your utility representative if three phase power is available at your farmstead.

DETERMINE COST OF THREE PHASE POWER:

- u Motor costs (usually lower)
- u Monthly utility service charges (may be higher, due to special metering equipment and transformers)
- u Cost for three phase line extension onto premises (if required)
- u Cost of three phase installation

If three phase power is not economically feasible at the desired site, the plans for electrical equipment may have to be changed. Equipment can often be chosen that will supply equivalent power with single phase, 120/240 V electric service. Consideration may also be given to an alternate site for new facilities with access to three phase

power. Another option is to use phase convertors to operate three phase motors from single phase service. Phase convertors can be used for equipment that starts easily—such as fans and pumps—but are not appropriate for equipment that requires a high starting wattage, such as silo unloaders.

If it is determined that three phase power is desirable and feasible, the electrical planning team should select a service voltage such as 120/208, 277/480, or 120/240 Volts.

DETERMINE SYSTEM CONFIGURATION FOR THREE PHASE POWER:

120/208 V 4-wire system

- u Will serve 120 V loads easily
- u Must select single and three phase motors that operate on 208 V—any 240 V heating elements must be derated to 208 V.
- u Majority of new farms are using this configuration because of advantages from safety, efficiency, and stray voltage standpoints.

277/480 V 4-wire system

- u Offers lower conductor and motor controller sizes and costs
- u Transformers needed to serve 120 V loads
- u Low line losses (voltage drop) associated with high voltage lines
- u Large, electrically complex operations using motors of 80 to 100 HP should consider this configuration

120/240 V 4-wire system

- u Will operate single and three phase loads
- u Be aware of the danger of connecting 120 V loads to the high voltage (208 V) phase of the system
- u Some utilities may not provide this configuration

Overhead or Underground Service

Overhead electric service is generally cheaper to install for both you and the utility, more convenient to service, and less susceptible to corrosion than underground wiring. Overhead service transformers are mounted on utility poles. Potential safety concerns exist where large farm equipment is operated near overhead wires.

Underground service usually is chosen for its reliability, safety, and aesthetic value. Underground wiring permits transformers and metering equipment to be located close to the service entrance panels without exposing the area to overhead line hazards. Underground wiring may cost more per linear foot but labor costs may be kept low if your power supplier will allow farm labor to dig the trenches. Transformers for underground service are mounted on the ground on fiberglass or cement pads that must meet utility specifications. Plan ahead so there is ample time for a cement pad to dry and cure before the transformer is installed.

A qualified electrician can give you price quotes for overhead and underground service.

Padmount Transformer for Underground Service

Space between transformer and building is required by code.

Types of Generators and Their Features		
	Manually-activated	Automatically-activated
TRACTOR DRIVEN	<ul style="list-style-type: none"> power supplied by power take off (PTO) shaft of tractor portable—can be used for other farm tasks requires operator to detect power failure, shut off loads, transfer power, start engine, and connect loads in sequence may be difficult to line up PTO, tractor may not start 	does not apply
ENGINE DRIVEN	<ul style="list-style-type: none"> power supplied by dedicated (permanently installed) engine requires operator to detect power failure, shut off loads, transfer power, start engine, and connect loads in sequence more convenient than tractor-driven may be unnecessary investment 	<ul style="list-style-type: none"> automatically senses power failure, shuts off loads, transfers power, starts engine, and connect loads requires no operator power restored almost instantly provides highest level of insurance an expensive option

Standby Generation

On today's farms, standby power is an essential insurance policy, not merely a service option. *During electric service interruption, standby power service can protect your livestock, your equipment, and your livelihood.* A standby electric power system consists of a generator, a power source (tractor or engine), a voltmeter, and a NEC-approved transfer switch to disconnect from the utility system and connect the generator to the farm electrical system.

Generators vary widely in complexity and cost. Standby power can supply your whole farm's electrical needs, or just provide the minimum power for the most essential farm loads. Three phase and single phase generators are available and generator type, for simplicity, should match power service.

For more information on standby power generation, refer to ASAE Standard EP 364, Installation and Maintenance of Farm Standby Electric Power, 1995.

Temporary Service

If you are building a new facility, the builder may want electric power before you are ready to install permanent service. Discuss this with your builder, then consult your power supplier about temporary electric service, if necessary.

Rate Options

Check with your utility representative about different billing methods. As your dairy expands, your billing status may change from residential to commercial. Several rate options, such as time of use (TOU) rates, may be available. Your utility representative will be able to help you choose the lowest-cost rate option.

In areas where electric supply cannot always meet demand easily (such as midday on a hot summer day when many air conditioners are running), some power suppliers will offer interruptible power rates to customers (i.e., large dairies). These utilities are offering financial incentive for customers who are willing to disconnect from utility power at peak demand times and use standby generators. Utilities may also offer rebates or discounts for customers who will oversize their standby generators in order to supply power back to the utility during peak periods—a practice that may or may not be economical. Special equipment will probably be required in order to supply power to the utility power grid.

Protection for Sophisticated Electronic Equipment

If your new facility requires electronic data collection or computer controls, you may want to talk with the equipment dealer and electrician about protecting this sensitive electronic equipment from even a momentary interruption in power.

UNINTERRUPTIBLE POWER SUPPLY (UPS)

A UPS protects your computer from power surges, loss of power, and voltage drops—all of which can damage a computer. A UPS will cost more and provide more protection than a power strip or surge protector. A UPS also allows time to save data and safely turn off computer equipment in case of power loss. If a

Temporary Service

UPS is not installed, a good quality surge protector should be used for computers and other electronic equipment.

DEDICATED CIRCUITS

Line disturbances such as voltage drops can be caused by starting or operating large loads or by other external factors. You can protect sensitive electronic equipment from potentially damaging loads by providing dedicated, or separate, circuits for electronic equipment. Work with your electrician and electrical contractor to identify circuits feeding sensitive electronic equipment. Keep these circuits free of large loads such as motors and heaters.

SITE CONSIDERATIONS

Article 547 of the National Electric Code describes wiring equipment and procedures for agricultural buildings where a damp, corrosive environment exists. Other practices to supplement the NEC can be found in the *Farm Buildings Wiring Handbook* and the *Agricultural Wiring Handbook*.

Beyond service entrance and transformer location, there are other site considerations related to electric service. Organize an on-farm meeting with the electrical planning team, general contractor, and subcontractors to address the following issues:

1. Will new service interfere with:
 - u water
 - u telephone
 - u gas

- u farm or vehicle traffic
- u access to the milking center
- u septic and well
- u tree lines and windbreaks?

2. Final grade must be established before underground service is installed.

3. Conduits must protect underground service wires installed under driveways from damage due to frost heaving.

PROPER GROUNDING

A proper grounding system is essential in agricultural buildings to ensure electrical safety and help reduce the risk of stray voltage. A qualified electrician should make sure your electrical



“An equipotential plane establishes a common voltage potential among all objects that animals can touch simultaneously, thus drastically reducing the risk of animal exposure to stray voltage.”



system is grounded according to the NEC. Failure to comply with the NEC will increase your fire and shock hazards. In some cases, additional grounding beyond the

NEC may be required to prevent or reduce stray voltage. Consult the *Farm Buildings Wiring Handbook* for detailed instructions on proper grounding. Experience has shown that the following grounding system modifications may help to protect livestock, workers, and equipment:

EQUIPOTENTIAL PLANE

Just like water flows from high to low elevations, current flows from high to low *voltage potentials*. When a cow simultaneously contacts two objects at different voltage potentials, the cow may become a path through which current can flow. An equipotential plane establishes a common voltage potential among all objects that animals can touch simultaneously, thus drastically reducing the risk of animal exposure to stray voltage. The NEC requires that an equipotential plane be installed in all new and extensively remodeled livestock buildings. Your electrician or power supplier can tell you if an equipotential plane is required on your farm.

FOUR-WIRE (SINGLE PHASE) AND FIVE-WIRE (THREE PHASE) SYSTEMS

Four- or five- wire systems significantly improve electrical safety and can help reduce stray voltage levels. These systems separate neutral and ground wires and are easily installed in new buildings with their own electrical service. The NEC requires separation of ground and neutral conductors in all facilities. Check with a qualified electrician to make sure these conductors are separated in a previously wired

building. Seek corrective measures if the ground and neutral conductors are not effectively separated in an existing building. For more information on four- or five- wire electrical service, see *Four-Wire Electrical Service for Farm Buildings*.

DEDICATED GROUNDING

You may also want to consider dedicated grounding to protect electronic equipment from ground faults and other grounding problems.

SAFETY

Safety is the first concern when designing and installing an electrical system. Improper design or installation can result in safety hazards that include electric shock and fire. Following is a short checklist of safety considerations. For more information on electrical safety on the farm, consult *Farming Safely and Efficiently with Electricity*.

- u Hire a qualified electrician who will follow the NEC and make certain the electrical work is inspected. The electric code is intended to ensure that safe and reliable electrical systems are installed.
- u Always use fixtures and materials approved for agricultural use by the NEC.
- u Keep fixtures clean and dry to avoid corrosion.
- u Ask your power supplier for information on minimum safe clearances from overhead and underground wires.

- u Consider underground wiring to avoid overhead line hazards.
- u Draw a detailed map of the underground wiring system. Never dig without consulting this map first. Be aware of other underground services such as gas, telephone, and water.

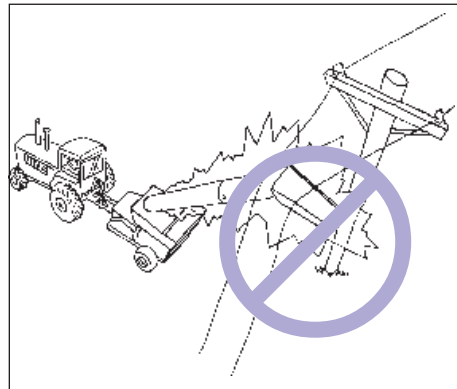

- u Never use tall farm equipment near overhead power lines.
- u Install a lightning protection system.
- u Have your qualified electrician ensure that the service entrance panel to each building is properly grounded.
- u Use Ground Fault Current Interrupters (GFCI) in damp or wet conditions. Don't use GFCI with continuously running motors (such as ventilation fans).
- u Maintain an effective rodent control program to reduce rodent damage to wiring.
- u Use only totally enclosed motors designed for farm duty.
- u Keep kids safe—locate electrical equipment out of reach of children.

ENERGY EFFICIENCY AND CONSERVATION

Discuss energy efficiency and conservation with your power supplier—they can provide information about energy efficient equipment and practices.

Energy efficient motors, lights, and fans and heat exchanger systems such as water preheaters and milk precoolers can be integrated into the design of a dairy facility. Some energy-efficient equipment may present a higher initial cost than its less energy-efficient counterpart, but often will pay for itself quickly in operational cost savings.

CONCLUSION

Plan ahead for a safe and effective electrical system for your expanded facility. Begin early to ensure ample time and resources are allotted for this critical aspect of your expansion. Don't forget to think about future changes in your operation!

Responsibility chart for electrical planning decisions.

Obviously, the dairy producer should be involved in all construction decisions. The table simply indicates who should always provide input on a particular subject.

<i>Decision</i>	<i>Dairy Producer</i>	<i>Power Supplier</i>	<i>General Contractor</i>	<i>Electrical Contractor</i>	<i>Equipment Vendor</i>
<i>location of service</i>	4	4	4	4	
<i>overhead/ underground</i>		4	4	4	
<i>phase selection</i>		4		4	
<i>voltage selection</i>		4		4	
<i>central service size (ampacity)</i>		4		4	
<i>service equipment selection</i>		4	4	4	
<i>standby power needs</i>	4		4	4	
<i>lighting</i>	4		4	4	
<i>motor selection</i>		4		4	
<i>branch circuit requirements</i>				4	
<i>motor protection</i>				4	4
<i>equipment disconnects</i>				4	
<i>grounding</i>		4		4	
<i>equipotential plane</i>		4	4	4	
<i>expandability</i>	4		4	4	4
<i>outbuilding capacity requirements</i>	4		4	4	
<i>surge suppression</i>	4			4	4
<i>lightning protection</i>			4	4	4

Information in this publication is from:

ASAE Engineering Practice 473, "Equipotential Planes in Animal Containment Areas,"

Cook, M.A., D.M. Dasho, D.J. Reinemann, and L.E. Stetson. "Electrical Service to Agricultural Buildings: Four-wire and Three-Wire Systems." ASAE Paper 953623. ASAE, St. Joseph, MI 49085. 1995.

Johnson, Eric L., "Determining Electrical Requirements for the Milking Center," in *Milking Center Design Conference—NRAES-66*. Northeast Regional Agricultural Engineering Service. Ithaca, NY. 1992.

Michigan Agricultural Electric Council. *Four-Wire Electrical Service for Farm Buildings*. Michigan State University Extension. East Lansing, MI. 1995.

Midwest Plan Service. *Farm Buildings Wiring Handbook—MWPS 28*, Ames, IA 50011. 1992.

National Fire Protection Association. *National Electric Code*. NFPA 70. Quincy, MA. 1996.

National Food & Energy Council. *Agricultural Wiring Handbook*. Publication No. 9002. Columbia, MO 65202.

National Food & Energy Council. *Electrical Wiring for Livestock and Poultry Structures*. Columbia, MO 65202.

Stetson, LaVerne E., "Design, Selection, and Installation of Electrical Wiring and Equipment," in *Designing a Modern Milking Center—NRAES-73*. Northeast Regional Agricultural Engineering Service. 1995.

Surbrook, Truman C., and R.C. Mullin, *Agricultural Electrification*. 1985. South-Western Publishing Company, Cincinnati, OH.

This publication was developed by the Wisconsin Farm Electric Council.

The mission of the WFEC is to initiate, develop, support, and coordinate education, research, and communication programs on significant and emerging rural energy issues for the consumer, energy suppliers, and allied industries through cooperative efforts of council members.

Related Publications from the Wisconsin Farm Electric Council

*Equipotential Planes for Stray Voltage Reduction
Farming Safely and Efficiently with Electricity*