

Electric Service Guide



People's Energy Cooperative

Your Touchstone Energy® Cooperative 

People's Energy Cooperative

Guide to Electric Service Rules and Regulations

Revised: May 2021

INTRODUCTION

People's Energy Copy (Hereafter referred to as PEC) has assembled this booklet to assist members and their electrical contractors, architects, or engineers to plan for and obtain electric service. The requirements herein supersede all previous publications the "Electric Service Guide" issued by PEC prior to the above date and is subject to change without notice. The most recent copy will be available on PEC's website.

PEC is not relieving our member, or their contractor, of the responsibility to install wiring in accordance with the National Electric Code® (NEC®), National Electric Safety Code® (NESC®), and all other applicable federal, state, and local government codes, regulations, laws, and ordinances. The information presented in this guide is intended to supplement the NEC, NESC, and all other applicable federal, state, and local government codes, regulations, laws, and ordinances. It is always necessary to refer to and comply with such codes, regulations, laws and ordinances when planning, designing, and installing a new electrical service, or modifying an existing electric service. Specific requirements of PEC do not intentionally conflict with any other requirements known to be in effect as of the publication date of this guide. Any apparent conflicts of this nature should be brought to the attention of PEC for interpretation. PEC assumes no responsibility whatsoever for the manufacturer's, supplier's, electricians', or engineering consultant's compliance with all applicable codes as well as with all local and state codes. Any waiver at any time of PEC's rights or privileges under the electric service rules and regulations will not be deemed a waiver as to any breach of other matter subsequently occurring.

All questions or requests should be direct to PEC's Engineering Department at engineering@peoplesenergy.coop, or (800) 214-2694.

This Electric Service Guide is available for download from PEC's website (<https://peoplesenergy.coop/electric-service>). Contact PEC for more details if needed.

People's Energy Cooperative Contact Information

Physical Address: 1775 Lake Shady Ave. So.
Oronoco, MN 55960

Web Address: www.peoplesenergy.coop

Contact	Phone Number	Email or Website
Main Office	507-367-7000	engineering@peoplesenergy.coop
Toll-free	800-214-2694	
General Fax	507-367-7001	
Distributed Generation	800-214-2694	derinterconnect@peoplesenergy.coop
Gopher State One Call	800-252-1166	www.gopherstateonecall.org

Electric Service Guide

Table of Contents

1.0	General Information.....	7
1.1	Definitions.....	7
1.2	Application for Service	11
1.3	Special Considerations	11
1.4	Availability of Service	11
1.5	Ownership of Electric Service Lines and Equipment	12
1.5.1	Overhead Electric Service	12
1.5.2	Underground Electric Service	13
1.6	Responsibility	13
1.7	Unauthorized Use of Energy and Meter Tampering	14
1.8	Carrier Current.....	14
1.9	Easements.....	14
1.10	Damage Liability	15
1.11	Standards and Specifications.....	15
1.12	New Service Minimum	15
2.0	Application Requirements.....	15
2.1	Site Plan	15
2.2	Utility Right-of-Way Easement and Property Description	15
2.3	Permits	15
2.4	Load Profile	15
2.5	Future Load	16
2.6	Additional Requested or Required Information.....	16
3.0	Pre-Construction Requirements	16
3.1	Service Point Location	16
3.2	Right-of-Way Clearing.....	16
3.3	Grade Requirements.....	16
3.4	Secondary Service.....	16
3.5	Construction Fee Charges	17
3.5.1	Estimated Costs.....	17
3.5.2	Unanticipated Costs.....	17

3.5.3	Major Line Extension Costs	17
3.6	Minnesota Wiring Affidavit or Inspection Certificate	17
4.0	Metering	17
4.1	General Metering requirements	17
4.1.1	Socket Bypass Required.....	17
4.1.2	Conductor Splicing.....	18
4.1.3	Ground Movement	18
4.1.4	Banner Boards.....	18
4.1.5	Member Disconnect Switch	18
4.1.6	Metering on poles	18
4.1.7	Special Sockets	18
4.2	Wiring Requirements	18
4.2.1	Location of high leg (Delta secondary 208 volt - wild leg).....	18
4.2.2	Line and Load side of CT Cabinets	19
4.2.3	Production Meter Wiring	19
4.2.4	Double Lugging.....	19
4.2.5	Proper Grounding	19
4.2.6	Neutral for Seven Terminal Sockets.....	19
4.3	Location and Accessibility.....	19
4.3.1	Location	19
4.3.2	Alternate Locations	19
4.3.3	Accessibility	20
4.3.4	Remodeling	20
4.3.5	Multiple Buildings or Tenants.....	20
5.0	General Construction Information.....	21
5.1	Service Connect Checklist	21
5.2	Route/Design/Method of Construction	21
5.3	Estimated Construction Schedule	21
5.4	Other Agreements	21
5.5	Line Extensions Not Connected.....	22
5.6	Trenching of Secondary Conductor to PEC Equipment.....	22
5.7	Pad-mount Transformer Clearances	22
5.8	Pad-mount Transformer pad specification.....	25
5.9	Connection Cabinet	26

6.0	Types of Service.....	26
6.1	Temporary	26
6.1.1	Secondary Service and Metering for Construction	26
6.1.2	Primary Voltage Service	26
6.2	New Permanent Primary Service	27
6.3	Emergency Service Disconnect	27
6.4	Incentive Rate Services	27
6.5	Electric Vehicle Charging Station Service	27
6.6	Standby/Emergency Backup Generators	27
6.7	Distributed Energy Resource (DER) interconnection	28
	Appendix A – Service Connect Checklist	29
	Appendix B – Approved Electric Meter Equipment	30
B.1	Approved Sockets.....	30
B.2	Sockets for Self-Contained Meters, Single Position	30
B.2.1	320 Amp Socket	30
B.2.2	200 Amp Socket	30
B.3	Service at 480 Volts.....	30
B.3.1	Single-Phase CT Service Socket	30
B.3.2	Poly-Phase CT Service Socket	30
B.4	Pad Mounted Secondary Metering Cabinets (CT Cabinets/ Transition Cabinets).....	31

1.0 General Information

People's Energy Cooperative (PEC) is providing this guide to help plan for new electric service or modify an existing service.

While we make every attempt to keep this guide up to date, it is subject to change without prior notice. It is the applicant/member and contractor's responsibility to contact PEC for the latest changes or revisions.

1.1 Definitions

Application for Service – The request from a member, or future member, to install a new electrical service or modify an existing service.

Accessible – Allowing or admitting, close approach; not guarded by locked doors, elevation, or effective means including any portion of a temporary or permanent structure.

Approved – Acceptable to the authority having jurisdiction.

Building – A structure with roof and walls. Two (2) or more structures shall not be considered a single building merely by the existence of skyways, tunnels, common heating or cooling facilities, common garages, entry halls or elevators, or other attachments.

Cold Sequence Metering – A disconnecting device that is located on the line side (before) of the metering equipment.

Contractor – Licensed individual or company who performs work on behalf of the member of PEC.

Construction Agreement – Signed contract between PEC and applicant/member outlining work to be performed by PEC, work to be performed by applicant/member, and a good faith estimate of construction fees under normal construction practices and conditions, good soil conditions and level terrain, and the design as discussed and agreed to by the applicant/member.

Current Transformer – An instrument transformer designed for the measurement or control of electrical current.

DER – the term DER is used to address all types of generation and energy resources that can be interconnected to the electric distribution system. DER technologies can include photovoltaic solar systems, wind turbines, storage batteries or diesel generators and are not limited to renewable types of technologies.

Disconnection Means – A device, or group of devices, or other means by which the conductors of an electric circuit can be disconnected from their source of supply.

Distribution Lines – PEC's electrical lines located along streets, alleys, highways, or easements on private property, when used or intended for use for general distribution of electric services to members.

Dwelling Unit – One or more rooms for the use of one or more persons as a housekeeping unit with space for eating, living, and sleeping, and permanent provisions for cooking and sanitation.

- Multi-Family Dwelling – A building containing two or more dwelling units.
- Single-Family Dwelling – A building consisting solely of one dwelling unit.

Easement – The right of use over the property of another, such as a right-of-way.

Electrical Service – The availability of electric power and energy, regardless of whether any electric energy is used. The supplying of electric service by PEC consists of the maintaining, at the point of service delivery, approximately the agreed voltage, phase, and frequency by means of facilities adequate for carrying the load which PEC is thereby obligated to supply by reason of the known requirements.

Electrical Work – The installing, maintaining, altering, repairing, planning, or laying out of electrical wiring, apparatus, or equipment for electrical light, heat, power, technology circuits or systems, or other purposes.

Fault Current – The electric current that will flow through the systems to a point where a piece or a conductor has failed, such as bare conductors touching together or a bare conductor touching a ground point.

Frost (Frozen Ground) – A condition where the water contained within the ground freezes, which may result in additional difficulty and expense in excavation work.

Hot Sequence Metering – A disconnecting device is not located on the line side (before) the meter.

Instrument Transformer – A transformer that reproduces in its secondary circuit, the voltage or current proportional to its primary circuit.

Instrument Transformer Cabinet – A cabinet installed and owned by the member, complying with PEC's requirements, and designed for housing instrument transformers used for metering. Also, referred to as a CT cabinet.

Junction Cabinet – A pad-mounted enclosure where underground primary cables are connected together, either by splices or separable connectors, for underground distribution systems. Also, referred to as a Test Cabinet.

Master Metering – Metering configuration where a single meter (master meter) measures the consumption for a building, and then sub-meters on the member side of the Master Meter measure the consumption of individual load, loads, or groups of loads.

Master/Meter Set – An instrument or instruments, together with auxiliary equipment, for measuring the electric power and energy supplied to a member.

Member – Any individual, firm, association, corporation, or governmental entity receiving electric service from PEC, currently or previously, at a specified location.

Member's Service Equipment – The necessary equipment and accessories, located near the point of entrance of supply conductors to a building, which constitute the main control and means of disconnecting the supply to that building, structure, or machine requiring electrical service.

NEC® – The current edition of the National Electric Code® as issued by the National Fire Protection Association (NFPA No. 70).

NESC® – The current edition of the National Electric Safety Code® as issued by the American National Standards Institute (ANSI C2).

Nominal Voltage – The value, expressed in volts, which is assigned to a circuit or system for the purposes of conveniently designating its voltage class (such as 120/240, 277/480Y, etc.). The actual voltage at which a circuit operates can vary from the nominal within a range established by ANSI C84.1. The member is responsible for making sure that their systems are capable of operating within range B of ANSI C84.1.

Occupancy Unit – A room, office, apartment, or other space separated by walls, or partitions that enclose the area, or a contiguous grouping thereof when occupied by a single member.

Parallel Service – Two or more services entering a building, allowed by all applicable codes, to serve separately metered loads of an individual member or members. Examples are services in multi-family dwellings, multi-occupant commercial buildings, and buildings with qualified member equipment served under a PEC incentive program.

Paved – A surface covered with a material such as stone, asphalt, or concrete designed for vehicular traffic.

PEC – People's Energy Cooperative

Point of Delivery – The point where the electric energy first leaves the line or apparatus owned by PEC and enters the line or apparatus owned by the member. This is not necessarily the point of location of PEC's meter.

Point of Interconnection – The location designated by PEC that the member must extend conduits to in order for PEC to install facilities on the member property.

Primary Service – Any type of service with a nominal voltage greater than 600 volts.

Rate Schedules – The classification of the use of electricity into categories considering the amount of power supplied, the purpose of its use, and the cost.

Redundant Facilities – Duplicate (partial or full) facilities installed at the request of the member for the purpose of increasing reliability of the system for themselves.

Secondary Connection Cabinet (Pedestal) – Cabinet required when the number and/or size of the conductors exceeds PEC's limit for terminating in a specific pad-mounted transformer.

Secondary Service – Any type of service with a nominal voltage less than or equal to 600 volts.

Secondary Terminal – The secondary side of a pad-mounted transformer, overhead transformer, service pedestal, or vault, whichever is designated by PEC.

Series Subtractive Metering – An arrangement to measure consumption for member equipment served under a PEC incentive program in series with one PEC master meter to measure total building consumption and a sub-meter(s) to measure the individual consumption of the equipment on the incentive program. For billing purposes, the consumption measured by the sub-meter is subtracted from the consumption of the master meter.

Service – The conductors and equipment for delivering energy from PEC's system to the wiring system of the member.

Service Drop – The overhead service conductors from the last pole or other aerial support, up to, and including the splices (if any), connecting to the service-entrance conductors at the building or other structure.

Service Entrance Conductors, Overhead System – The service conductors between the terminals of the service equipment and a point usually outside the building, clear of building walls, where joined by tap or splice to the service drop.

Service Entrance Conductors, Underground System – The service conductors between the terminals of the service equipment and the point of delivery.

Service Equipment – The necessary equipment, usually consisting of a circuit breaker or switch and fuses, and their accessories, located near the point of entrance of supply conductors to a building or other structure, or an otherwise defined area, and intended to constitute the main control and means of cutoff to the supply.

Service Upgrade – An electric service is considered upgraded if any of the following conditions are met:

- If the rating of the member disconnect is increased.
- If the main service disconnect type is changed (i.e. from fuses to circuit breaker) or replaced (i.e. circuit breaker to circuit breaker)
- If either the conductors between the meter socket and the member disconnect or the conductors on the supply side of the meter are changed.
- If the service is changed from overhead service drop to underground service line.

Underground Distribution (URD) Areas – Those residential or commercial subdivisions, or specified areas, within which all consumers are serviced by underground distribution lines.

Underground Service Lateral – The secondary service conductors from PEC's distribution system.

Unsuitable Backfill Material – Includes, but is not limited to, the following materials:

- Granular material (individual stones, soil in clumps or clods, etc.) larger than 1/4 inch in diameter
- Frozen materials
- Materials removed as rock excavation or over-excavation
- Trash, metal, or construction waste
- Environmentally contaminated soils

Voltage to Ground – For grounded circuits, the voltage between the given conductor and that point or conductor of the circuit that is grounded; for ungrounded circuits, the greatest voltage between the given conductor and any other conductor of the circuit.

Voltage Transformer – An instrument transformer intended for use in the measurement of control of a circuit and designed to have its primary winding connected in parallel with the circuit.

1.2 Application for Service

Members, potential members, or their authorized representative should apply for new service, line extensions, and service improvements as far in advance as possible to avoid delays.

New service, line extensions, or service improvements requests should be made by completing the appropriate online application on PEC's website at www.peoplesenergy.coop/electric-service or by calling 800-214-2694 if you are unable to access the application. A Field/Staking Engineer will contact you normally within one business day, but not more than three business days to discuss your request.

1.3 Special Considerations

- When a service crosses public streets or roads, PEC must comply with government regulations and obtain special permits which may require public hearings.
- When an underground or overhead line will cross property of others, easements must be obtained from the landowner.
- Trees that pose a risk to current or future reliability of a new or existing line must be trimmed or removed.
- All permits and easements must be properly executed and obtained before service can or will be installed or upgraded.
- A construction agreement must be signed, and fees paid before construction will be scheduled.

1.4 Availability of Service

PEC shall provide electric facilities necessary to deliver electric service to new locations within its service territory to anyone meeting requirements for membership. The cost of extending PEC's facilities for new service requests shall be shared by the requesting member in a manner that guarantees the extensions and improvements are prudent and

provide for the recovery of these investments on a reasonable basis without a significant impact on present and future members.

Prior to designing or altering electrical installations, the member, architect, engineer, and/or contractor must consult with a PEC engineer to ensure availability of the desired service, ensure member's electrical equipment is compatible with PEC facilities, and to determine if PEC has requirements in addition to those in this guide.

PEC supplies 60 Hertz alternating current, single- or three-phase. The following are the standard voltages that PEC provides:

Single-phase voltage:

240/120 Volt, 3 wire

Multi-phase grounded "wye" voltages:

208/120 Volt, 4 wire

480/277 Volt, 4 wire

Contact PEC for other available voltages.

Exact service specifications such as voltage and number of phases depend upon the location in question and the proposed load's size, location, and nature. PEC does not accept responsibility for oral information concerning the type of service available at specific locations. An authorized PEC representative must confirm the information in writing.

1.5 Ownership of Electric Service Lines and Equipment

The primary electric distribution lines and equipment installed by PEC shall remain the property of PEC. Any payments made by the applicant for the service extension shall not transfer ownership or control rights to the applicant over these facilities.

1.5.1 Overhead Electric Service

In new installations, the member shall own and maintain all equipment beyond the transformer or other secondary terminal point. This equipment includes, but is not limited to, the overhead secondary wire, the meter pole or mounting structure, the service drop wire holder or bracket, the weather head and service mast with conductors, and the meter socket.

In all cases, in locations where the Cooperative installs overhead secondary service wire, to serve multiple services, as under-build on primary distribution poles, the Cooperative will maintain ownership of said wires and the provided connection point for the member's service drop.

In services installed prior to 1996, the Cooperative owns and is responsible for maintaining the overhead service drop to the service entrance conductors extending from the weather-head of the service mast or pole-top switch. In situations where the overhead secondary service drop is connected at the weather-head of a service mast, the point of ownership changes at the point of connection to the service entrance conductors. The member shall own and be responsible for the service drop wire holder or bracket, the weather head and service mast with conductors, and the meter socket.

In the event secondary conductors are replaced, the ownership of the new conductors (service drop) from the service transformer, or other defined connection point, to the service entrance connectors shall be transferred to the member. The member should contact the Cooperative to verify the ownership of the secondary conductors for the existing service in question.

In all cases, the member owns and is responsible for the wires from the meter socket to other locations or buildings, any disconnect switches or breaker panels at the meter, the meter socket, and mounting panel.

1.5.2 Underground Electric Service

In new installations, the member shall own and maintain the underground cable running from the transformer or pedestal to the meter socket, including the wiring and connections. The meter shall remain the possession of the cooperative.

In services installed prior to 1996, the cooperative owns and is responsible for maintaining the wires running from the transformer or pedestal to the meter socket and the meter. The member still owns the meter socket and all wiring beyond the metering point. In the event the secondary wire from the transformer to the meter socket is replaced, the ownership of the new wire shall be transferred to the member. The member should contact the Cooperative to verify the ownership of the secondary wire for the existing service in question.

In all cases, the member owns and is responsible for the wires from the meter socket to other locations or buildings, any disconnect switches or breaker panels at the meter, the meter socket, and mounting panel.

1.6 Responsibility

Following the rules and regulations set forth by the authority having jurisdiction, the National Electrical Safety Code (NESC), National Electric Code (NEC), state and local codes, and People's Energy Cooperative requirements, will guarantee acceptable installation. PEC reserves the right to disconnect service if unsafe conditions exist or a member does not comply with all rules and regulations.

1.7 Unauthorized Use of Energy and Meter Tampering

Meters, instrument transformers, or metering devices shall not be tampered with. Meter sealing rings, locking devices, and meter seals shall not be cut or removed. Property of PEC shall not be moved, removed, or altered in regard to wiring or connections by another, other than authorized PEC employees, except in emergency situation due to fire or immediate endangerment of life and property.

PEC will enforce Minnesota Statute 325E.026 which prohibits unauthorized use of electricity and utility meters. A utility may bring a civil action for damages against a person who: (1) deliberately commits, authorizes, attempts, solicits, aids, or abets bypassing, tampering, unauthorized connection, or unauthorized metering that results in damages to the utility; or (2) knowingly receives service provided as a result of bypassing, tampering, unauthorized connection, or unauthorized metering. The utility may recover costs of the service provided; the costs and expenses for investigation, disconnection, reconnection, service calls, equipment, and employees; and the trial costs and witness fees.

1.8 Carrier Current

PEC reserves the right to use carrier frequency signals on its system for communication, equipment control, and system data collection and will not be held responsible for damages resulting from such frequency signals. If such frequency signals damage or interfere with a member's equipment, the member should install suitable protective equipment. PEC forbids members to use any part of our system for carrying foreign electric currents, broadcasting, control, or carrier current transmission. Members using carrier current or any control frequency other than 60 Hertz shall be required to install suitable equipment to prevent these frequencies from entering PEC's system.

1.9 Easements

Whenever any overhead or underground cable or equipment owned by PEC is located on the applicant's property, the applicant shall grant an easement to PEC by signing the "Electric Service Membership Application". PEC may request an additional easement form to be signed which contains the legal description of the easement and parcel description. This document will be filed at the County Recorder's Office. All electric distribution line easements are to be granted at no cost to PEC.

If any overhead or underground cable or equipment owned by PEC must be located on property not owned by the applicant, PEC will attempt to seek such easements. However, if PEC is unsuccessful in obtaining the easements with a reasonable effort, it is the applicant's ultimate responsibility to obtain the easement for filing as set forth in the above paragraph. If easements cannot be obtained for the preferred route, the applicant shall be responsible for the actual line extension route necessary to provide electrical service.

1.10 Damage Liability

PEC will not be liable for damage to the applicant's crops, trees, shrubs, fences, lawns, sidewalks, driveways, or other obstructions incidental to the installation, maintenance, or repair of facilities if such damage was not caused by its own negligence.

1.11 Standards and Specifications

All electric facility additions and improvements shall be designed and installed to meet or exceed the requirements and specifications of the NESC, NEC, state and local codes, and approved design standards of PEC.

1.12 New Service Minimum

The applicant shall agree to maintain a new service for a minimum of 60 months and pay the basic monthly charge during this time.

2.0 Application Requirements

The applicant, or their representative, shall provide the information, agreements, and permissions necessary to allow PEC to extend the appropriate facilities for the load to be served. Facilities installed by the applicant shall meet all requirements of the NEC, NESC, state and local codes, and PEC.

The applicant shall provide the following before designing/engineering of the new service or modification of facilities can begin:

2.1 Site Plan

Applicant shall meet with a PEC representative at the service location to coordinate site requirements and provide a site plan of existing or anticipated structures or facilities both above ground and/or underground including the location of property corners.

For residential and commercial subdivisions, a copy of the approved general development plan and the applicable final plat shall be provided to PEC.

2.2 Utility Right-of-Way Easement and Property Description

Easements shall be required as outlined in Section 1.9. In addition, a legal property description must be submitted.

2.3 Permits

Applicant shall provide a copy of the building/zoning permit. Proof of property ownership may be required.

2.4 Load Profile

Applicant shall provide applicable load survey information including the projected peak and nominal load capacity, utilization (type of load, seasonal or year-round), and projected motor sizes and numbers.

2.5 Future Load

Applicant shall provide any anticipated plans to expand and/or possibly increase load capacity during the following five years after construction is commenced.

2.6 Additional Requested or Required Information

PEC may request or require additional information or assistance that is necessary for the engineering and construction of work.

3.0 Pre-Construction Requirements

Upon execution of the Construction Agreement, the applicant shall complete the following items prior to the project being scheduled for construction:

3.1 Service Point Location

Applicant shall review and accept the proposed location of the electric facilities as staked by the Field/Staking Engineer as well as other requirements and conditions.

3.2 Right-of-Way Clearing

Applicant shall be responsible for the cost of the right-of-way clearing along the entire line extension route in accordance with PEC specifications. The applicant may perform right-of-way clearing within their property boundaries. PEC shall perform right-of-way clearing along public roadways and bill the applicant for the costs.

3.3 Grade Requirements

Applicant shall have areas in which electric facilities are to be installed within four inches of finished grade prior to the start of the installation of cooperative facilities.

3.4 Secondary Service

Applicant is responsible for the installation of the secondary service line, meter loop and socket, and the service entry. These need to be constructed in accordance with the NEC, NESC, state and local codes, and the specifications of PEC. Newly installed service lines shall not contain splices between the transformer and the meter socket.

A secondary terminal point will be defined and provided by PEC. The secondary terminal point can be the secondary terminal of a transformer, a secondary pad mounted pedestal, or an overhead secondary junction point on a primary voltage pole owned by PEC.

PEC shall provide, own, and maintain the meter and associated current and potential transformers. The main service entrances, meter loops, meter socket, and proper facilities must be furnished and installed by the applicant or applicant's contractor per PEC Standards.

3.5 Construction Fee Charges

The applicant must be in good financial standing, having no past due or delinquent debt owed to PEC.

3.5.1 Estimated Costs

Estimated costs will be included in the Construction Agreement. All estimated fees are to be paid prior to the start of construction.

3.5.2 Unanticipated Costs

An extraordinary construction costs such as permit fees, obstacles, rough terrain and rocky soil conditions, unanticipated contractor surcharges, or other unusual situations involving unique practices in the construction and/or ongoing operation and maintenance of the line extension shall require the applicant to reimburse PEC for such costs. This shall include, but not be limited to, added costs to install primary underground cable during winter months when frost is present.

3.5.3 Major Line Extension Costs

Provisions shall be provided for the prorating of major line extension contributions to subsequent users, including possible refunds to the original applicant.

3.6 Minnesota Wiring Affidavit or Inspection Certificate

All wiring shall be completed in strict accordance with the State and local electrical laws and regulations and will conform to the rules as outlined in the NEC and NESC. When an electrical contractor is used, a Minnesota electrical wiring affidavit shall be provided by the applicant. If electrical work is done by the owner, a Minnesota electrical wiring affidavit and final electrical inspection shall be provided to the Cooperative before the service will be connected.

4.0 Metering

Meter socket standards are published in PEC's Approved Electric Meter Equipment document as provided in **Appendix B**. Meter sockets and CT cabinets on this list shall be used unless otherwise approved in writing by the PEC Metering Department.

Meter sockets and metering cabinets are to be furnished by the applicant. PEC allows self-contained meter sockets for residential services up to 400 amps and up to 200 amps for commercial services.

4.1 General Metering requirements

Any exceptions to the requirements below shall be approved by PEC Metering personnel.

4.1.1 Socket Bypass Required

All self-contained meter sockets used for new or rewired installations must have an approved lever bypass mechanism. The house meter for apartment buildings requires lever bypass switches. This requirement is for both single- and three-phase services at all

voltages. PEC requires the billing meter socket to be updated to a lever bypass meter socket when applicant is interconnecting a DER system to their service.

4.1.2 Conductor Splicing

New service lines, whether for a newly installed service or a replacement of an existing service, shall not be spliced in the meter socket.

4.1.3 Ground Movement

A slip sleeve or expansion joint shall be furnished and installed by the applicant on all new and rewired underground residential meter installations and recommended for all commercial installations. Meter sockets shall contain sufficient conductor length to allow movement during ground freeze/thaw cycles.

4.1.4 Banner Boards

All banner board installations require the use of 6"x6" green treated posts, set a minimum of three (3) feet in depth, and a minimum of 2"x 6" green treated banner board construction, with a preference of 2"x 6" green treated tongue and groove boards. A minimum clearance depth of three (3) feet in front of the meter must be provided for access for maintenance. For service upgrades or DER installations, applicants shall be required to update their banner boards to PEC's latest spec (if the existing banner board is in poor condition).

4.1.5 Member Disconnect Switch

Member disconnect switches should be connected on the load side (after) of the meter. No member devices such as surge suppressors, load management equipment, etc. may be installed on the line side (before) of the meter.

4.1.6 Metering on poles

Pole top switches and metering sockets shall not be located on PEC-owned poles; however, if no other placement of the meter socket is possible, prior approval, in writing by PEC's Engineering Department, can be requested. An exception is metering requiring external potential and/or current transformers, which will be owned by PEC.

4.1.7 Special Sockets

All special sockets, such as apartment panels, recessed, mobile home parks, socket and switch, or socket and transfer, must have PEC's approval prior to installation.

4.2 Wiring Requirements

4.2.1 Location of high leg (Delta secondary 208 volt - wild leg)

The conductor with the higher voltage to ground must be connected to the terminal on the right side. The high-leg conductor must be identified as required by the NEC. Meter sockets with the high-leg in the wrong position will not be energized. Mis-wired sockets will be subject to disconnection until correct socket is installed. The high-leg in all CT cabinets shall be on the right side in order to be energized.

4.2.2 Line and Load side of CT Cabinets

In all CT cabinets the line side and load side shall be clearly marked.

4.2.3 Production Meter Wiring

PEC requires all DER installations to include a Production meter. The applicant shall furnish the production meter socket or CT cabinet. Production meter sockets shall be wired with the load side at the top and the line side at the bottom. PEC prefers that the production meter be located upstream from any customer disconnects.

4.2.4 Double Lugging

Double lugging is only permitted on meter sockets for distributed energy resources with prior approval.

4.2.5 Proper Grounding

All metering conduits and sockets shall be properly grounded. No bonding bridges will be permitted on the exterior of the meter socket. The grounding electrode conductor shall not be pulled through or connected in the meter socket. Electric service will not be connected to improperly grounded systems.

4.2.6 Neutral for Seven Terminal Sockets

A system neutral is required to each seven-terminal socket. The minimum conductor size is #6 wire.

4.3 Location and Accessibility

4.3.1 Location

All meters shall be located on the outside of the building receiving service or other structures at a height that allows access by PEC personnel in an unaided standing position which does not require stooping or reaching overhead. The height as measured at the bottom of the meter socket should be no less than 48 inches and no more than 65 inches.

A minimum 3' radial distance must be maintained between any gas regulator and meter sockets.

If more than one meter is required for a building, each meter socket shall be identified and permanently designated clearly indicating each particular location being served. This marking needs to be on weatherproof material and of at least ½ inch block letters. This also needs to be done on the inside of the meter socket in the event of a cover being changed.

4.3.2 Alternate Locations

Special approval for an alternate location may be considered for certain three-phase installations. Such locations must be pre-approved by PEC Metering Department in writing, prior to installation.

4.3.3 Accessibility

The meters are to be readily accessible with clearance to the sides, above, and in front of the meter to allow proper access for regular and emergency maintenance as shown below in Figures 4.1 & 4.2. The member shall pay any costs associated with moving non-accessible meters or removing obstructions. The member is responsible for any damage caused during an emergency due to the inability to disconnect service at the meter due to inaccessibility.

Top Down View

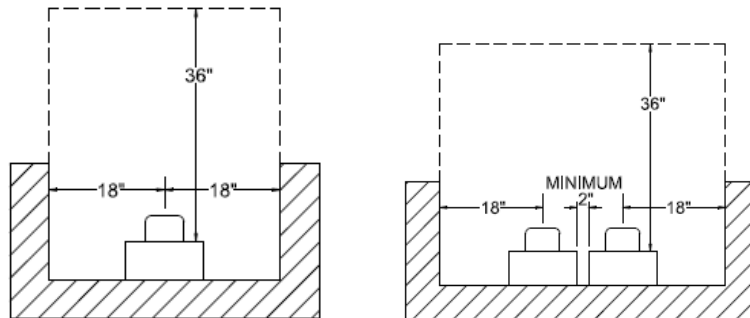

Figure 4.1 – Single Meter

Figure 4.2 – Multiple Meters

1. Area within dashed lines shall be clear of all obstructions.
2. Eighteen-inch (18") clearance shall be maintained to either side of the center line of the meter socket.
3. Thirty-six-inch (36") clearance shall be maintained in front of meter socket unless otherwise specified in NEC.
4. The height as measured at the bottom of the meter socket should be no less than forty-eight inches (48") and no more than sixty-five inches (65").

4.3.4 Remodeling

When remodeling occurs, the member shall take the steps necessary to relocate the meter to meet the specifications identified in this section.

4.3.5 Multiple Buildings or Tenants

- Multiple members or building sites shall not share metered accounts unless that account only services a shared (co-owned) well or wastewater treatment facility.
- The main residence and farm buildings may be metered on one meter however, it is not preferred.
- The main residence, well, and outbuilding may be metered on one meter.
- Wells serving multiple homes must be metered separately.
- Additional tenant (leased) housing or other residence on the property shall be metered and billed separately.

- Commercial establishments such as mobile home courts, apartment buildings, campsites, or multi-tenant commercial lease space shall be designed so that the electric energy used by each mobile home, apartment, campsite, or leased commercial space is metered separately unless otherwise agreed to by PEC.
- A business entity with multiple buildings or service points may be worked out with PEC as a “campus” arrangement for one service point of metering at the entrance of the facility site. Such a metering point may be installed at primary voltage levels. The member shall enter into an electric service agreement which defines the metering point, service delivery point (or points), and ownership of all primary and secondary electrical wire and equipment installed between the member side of the primary metering point and the service delivery point(s). The member shall own all primary and secondary wire and equipment on the member side of the service delivery point(s). The agreement between the member and PEC is required to be in place prior to implementation of a primary metering installation.
- Energy provided at a primary metering point, whether in a building with multiple tenants, a campus with multiple buildings, or a mobile home park, or other type of service may not be resold.

5.0 General Construction Information

5.1 Service Connect Checklist

Appendix A is a Service Connect Checklist. Please be sure all the items on the checklist are completed before contacting PEC for a service connect.

5.2 Route/Design/Method of Construction

PEC reserves the exclusive right to determine the route, design, whether overhead, or underground facilities, and method of construction as it deems appropriate and necessary. If the applicant desires an alternative method or route of construction, the applicant shall pay all the additional costs associated with the alternative if it is accepted by PEC as a feasible method of installation.

5.3 Estimated Construction Schedule

At the time all pre-construction requirements are met, the applicant shall indicate if the project should proceed and PEC shall indicate an estimated construction schedule. This estimated schedule is subject to revision due to unforeseen circumstances such as line repairs and maintenance work to restore power, equipment breakdown, unavailability of materials, construction obstacles, or weather that delay progress. If the applicant elects not to proceed with the project within twelve months, the applicant shall be required to reapply under the line extension policy in effect at that time.

5.4 Other Agreements

Agreements, if any, for service types other than primary service to the site (such as dual fuel, standby generator electric service, or lighting) shall be signed and submitted.

5.5 Line Extensions Not Connected

Extensions not connected for normal service within six months from project completion by PEC shall be subject to a line retention fee. The fee will be a monthly billing equivalent to the monthly facility charge for the rate class for the planned load served by the extension or modification. The line retention charge will continue until PEC's investment is recovered.

5.6 Trenching of Secondary Conductor to PEC Equipment

Before energizing electric service, all trenching of secondary conductors to PEC equipment shall be completed. It is recommended that the conductors be placed in conduit. If the equipment is a pad-mount device (transformer, secondary pedestal, etc.) the cable should be brought to the device with six (6) feet of extra cable for a secondary pedestal and ten (10) feet of extra cable for a transformer to allow for proper connection to PEC equipment. If the equipment is a pole mounted transformer, the applicant shall install the conduit and weather head to a height of two feet below the base of the transformer with ten (10) feet of extra cable to allow for proper connection to PEC equipment.

5.7 Pad-mount Transformer Clearances

Noncombustible Walls

(Included in this class would be wood framed, brick-veneered buildings, metal clad, steel-framed buildings; asbestos cement-board walled; metal-framed buildings; and masonry buildings with a one-hour fire rating.) Pad-mount oil-insulated transformers may be located a minimum distance of 3' from the roof overhang of a noncombustible walled building if all the clearances are maintained as noted in the figures below for doors, windows, and other building openings.

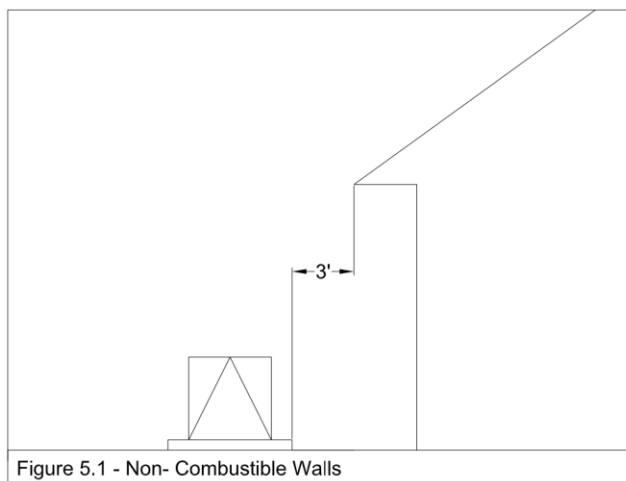

Doors

The required transformer clearances for Noncombustible walls with Doors is shown below in Figure 5.2.

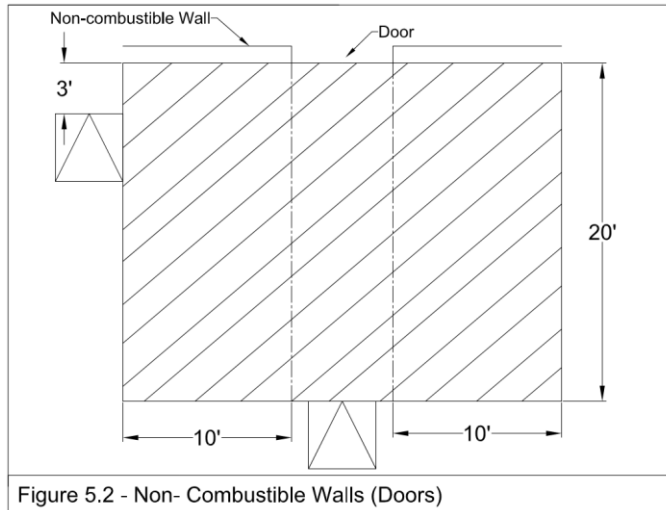

Building Openings

The required transformer clearances for Noncombustible walls with Building openings is shown below in Figure 5.3. If the opening is located above the transformer, the distance from the top of the transformer to the opening shall be a minimum of 10'.

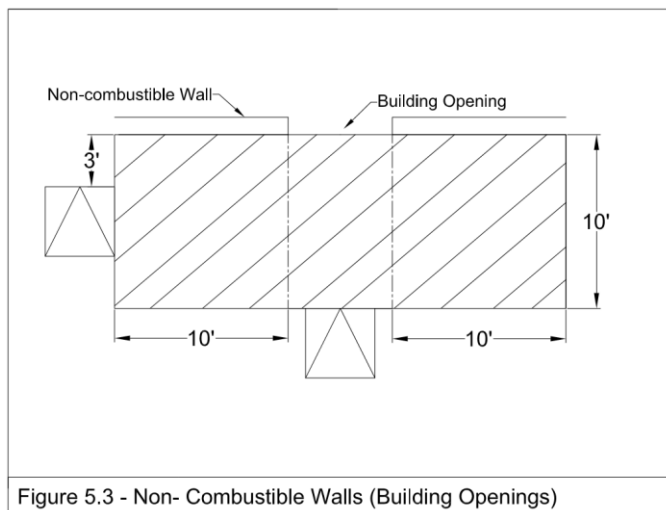

Combustible Walls

(Included in this class would be wood buildings and metal clad buildings with wood frame construction.) Pad mount transformers shall be located a minimum of 10' from the building as shown below in Figure 5.4 in addition to the clearance from doors and building openings set forth for noncombustible walls.

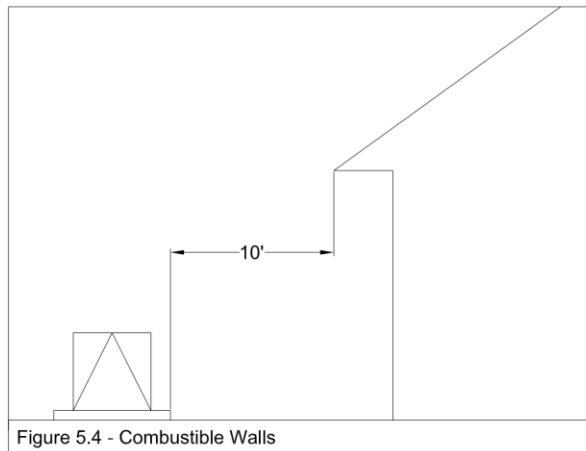

Barriers

(Included in this class are reinforced concrete, brick, or concrete block barrier walls with a three-hour fire rating.) If the clearance in previous section cannot be obtained, a fire-resistant barrier shall be constructed in lieu of the separation. Contact the engineering department for clearance questions involving fire-resistant barriers.

5.8 Pad-mount Transformer pad specification

For three phase pad-mounted transformer installations the applicant is required to furnish the transformer pad and conduit sweeps. Please note PEC reserves the right to request a review of the formed pad before applicant pours the pad. Refer to PEC's pad specification below in Figure 5.5.

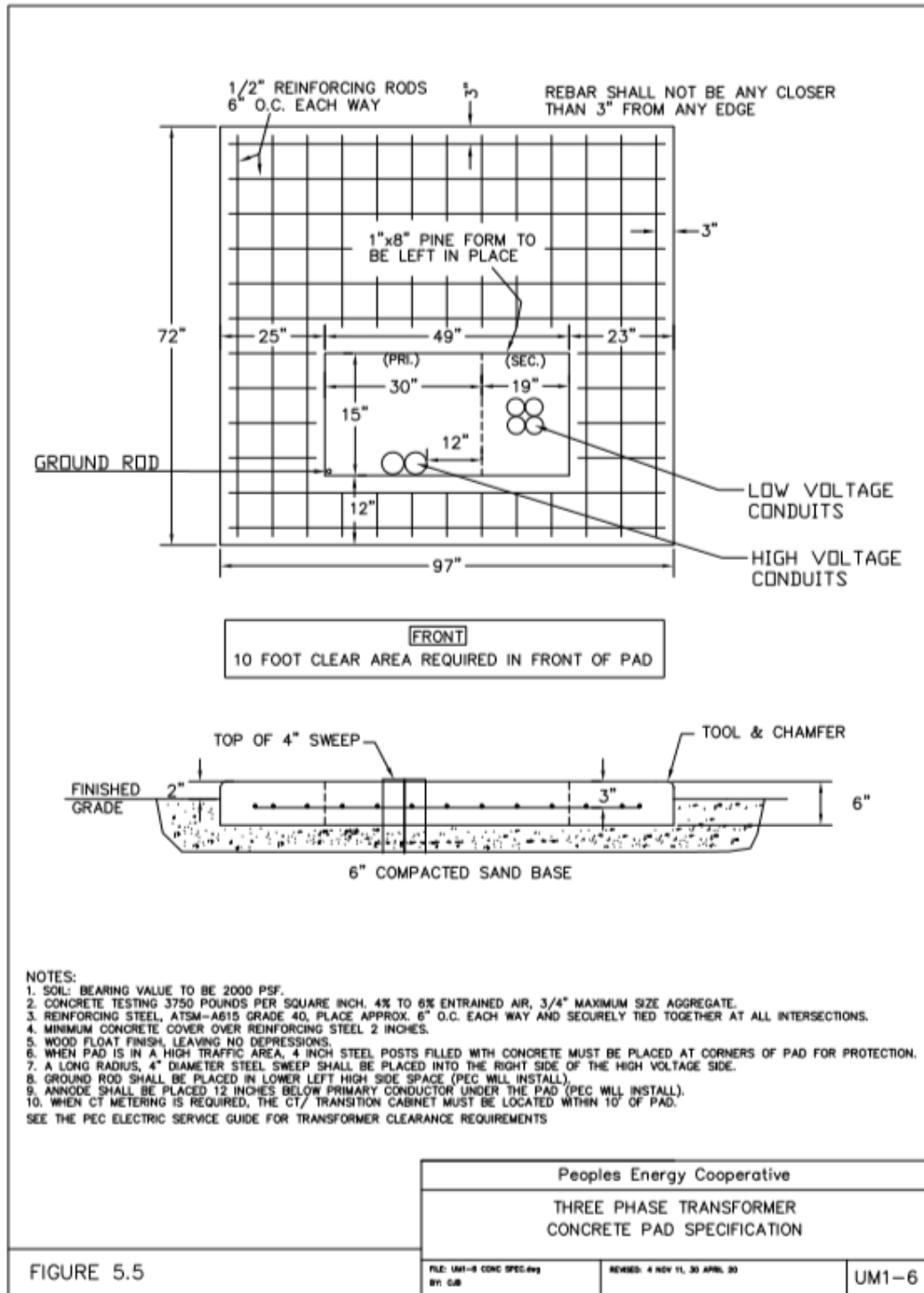

5.9 Connection Cabinet

Applicants shall furnish and install a member owned connection cabinet where the number of secondary conductors exceed the transformer limitations. PEC will make secondary connections in the transformer and in the connection cabinet. PEC will install a lock on the connection cabinet. Contact PEC Engineering Department for more details on member owned connection cabinets.

6.0 Types of Service

6.1 Temporary

Temporary service extensions shall meet NEC and NESC requirements and be acceptable to PEC for location and installation. There are two types of temporary services.

6.1.1 Secondary Service and Metering for Construction

A temporary metered construction service may be installed at the request of the applicant or contractor. The service must be a secondary tap from an existing primary line and transformer. If a transformer is not presently in place, and the temporary service cannot use the planned permanent transformer, then the applicant is subject to a fee for installation and removal of a temporary transformer.

The secondary line and a temporary meter socket shall be provided by the applicant. The applicant shall pay a fee for the temporary meter installation.

Temporary metered services shall be reviewed twelve months after installation. At that time, the service shall be converted to a permanent account, possibly granted an extension of temporary service by PEC, or terminated.

All temporary service for construction will be metered with a monthly minimum service charge at the appropriate service class rate.

6.1.2 Primary Voltage Service

Temporary extension of primary service is the installation of primary voltage facilities (lines, poles, and transformer) to support the applicant's construction prior to the installation of the planned permanent facilities. Temporary primary voltage services are those that will likely be used for a period of twelve months or less.

If a temporary primary voltage extension for service is requested, the applicant shall pay the actual construction costs, actual retirement costs less salvage material, plus electric usage, and other associated costs.

6.2 New Permanent Primary Service

PEC will extend its primary single- or three-phase electric service to a permanent structure or service such as a home or business that will be utilized on a year-round basis. Fees are based on total footage cost for individual services and a combination of per lot and extended footage for platted subdivisions.

6.3 Emergency Service Disconnect

One- and two-family dwelling unit services are required to have an emergency service disconnect switch per the 2020 National Electric Code and Rules adopted by the Minnesota Board of Electricity. The switch must be wired on the load side (after) of the meter, outside of the structure adjacent or near the meter socket, and free from obstructions such as HVAC equipment, decks, or shrubbery.

6.4 Incentive Rate Services

PEC offers incentive programs/rates such as, but not limited to dual fuel, off-peak heating storage, and electric vehicle charging. As part of participating in these programs, a separate service entry, which is in parallel to the main service, is required to be installed to provide electricity to the systems panel. A meter socket with a lever by-pass is required for the incentive rate meter.

Control wiring is also required to be run from the control panel of the system, to an agreed upon location next to the meter, to allow for control under the incentive program. This wiring will be connected to the equipment used to communicate to the system under the rules of the program.

For systems with larger controls, the Cooperative's engineering department will need to be consulted on whether a separate secondary voltage line from the service transformer is required.

6.5 Electric Vehicle Charging Station Service

For the installation of a level 3 charging station, PEC requires a separate service entry, which is in parallel to the main service. This is also recommended for level 2 chargers. For both level 2 and level 3 charging stations, PEC requires notification from the member to allow for verification of available service transformer capacity for the new load.

6.6 Standby/Emergency Backup Generators

PEC requires a) an accessible disconnect switch be installed for the safety of its crews and the public, and b) the member notify the Cooperative for the existence of the backup generation/source. These requirements are independent of the backup generation/source being a temporary generator connector only during time of outages, or the backup generation/source being a battery system or generator permanently wired to the service with a utility rated automatic load transfer switch.

6.7 Distributed Energy Resource (DER) interconnection

PEC has adopted the Cooperative Minnesota Interconnection Process (C-MIP) and technical requirements documented within IEEE Standard 1545 as its implementation of Minnesota Statute 164B.1611. As part of the interconnection, PEC requires the installation of a production meter for DER facilities which qualify for net-billing, or for services that offset load using electricity generated by the DER facility. The C-MIP process can be viewed on the Cooperative website. Questions on the process, or specific to a possible DER installation, can be sent to the DER Coordinator at DERinterconnect@peoplesrec.com.

Appendix A – Service Connect Checklist

Electrician/Installer doing the work: _____

Service address: _____

Date service is ready: _____

Items completed:

- Service wire is installed.
- Service wire is backfilled.
- Service entrance is installed.
- Service panel cover is installed.
- Service wire is installed at proper depth.
- Service wire length is adequate to reach PEC connection point.
- Service wire is trenched to correct connection point.
- Service wire is correct size to meet PEC and NEC requirements.
- Service wire is not damaged.
- Temporary service has ground fault breaker.
- Service wire neutral has been identified.
- 200 amp jaw clamping lever bypass is installed. For service above 200 amps call PEC.
- Meter socket height is installed at no less than 48" and no more 65 inches.

Questions to ask PEC: _____

Appendix B – Approved Electric Meter Equipment

B.1 Approved Sockets

Refer to the sections below for PEC approved meter sockets and secondary metering connection cabinets. Meter installations made with unapproved sockets or cabinets will not be energized. Services energized with unapproved equipment will be subject to disconnection until the service is corrected.

B.2 Sockets for Self-Contained Meters, Single Position

Residential use – All are ringless, weatherproof, four terminal, 600 volts or less and require a manual bypass. Overhead and underground shall have 200-amp minimum sockets. An approved manual bypass must be on 320-amp sockets.

<u>Manufacturer</u>	<u>Part Number</u>	<u>Overhead (OH)/Underground (UG)</u>
B.2.1 320 Amp Socket		
Talon	320A 4J RGLS 1POS LVRBPS MS	OH/UG -SW
Milbank	U1079-R	OH
	U1129-O-K3L-K2L	UG
B.2.2 200 Amp Socket		
Milbank	U4801-XL	OH/UG
	U9318-XL	OH
	U9319-XL	OH/UG
Talon	200A 4JRGLS 1POS NO BPS MS	OH/UG

B.3 Service at 480 Volts

Meter sockets used on 480-volt service must have a flash shield over the jaws and an approved bypass mechanism. The only approved meter sockets for 480-volt use are 200-amp commercial types. Self-contained 480-volt services require cold sequence metering.

<u>Manufacturer</u>	<u>Part Number</u>	<u>Overhead (OH)/Underground (UG)</u>
B.3.1 Single-Phase CT Service Socket		
Milbank	U4490-XL (6-terminal Lever Bypass)	OH/UG
B.3.2 Poly-Phase CT Service Socket		
Milbank	U4493-XL (13-terminal Lever Bypass)	OH/UG

B.4 Pad Mounted Secondary Metering Cabinets (CT Cabinets/ Transition Cabinets)

Secondary metering cabinets with donut and/or bar type CT mounting provisions are to be used for metering large underground services.

All cabinets shall be constructed of galvanized and painted steel. No side-entry raceway will be allowed from the transformer to the connection cabinet.

The following connection cabinets with CT mounting provisions have been approved for use in the PEC service area. Any cabinet not on this list will require prior approval by PEC Engineering Department before the service will be connected.

<u>Manufacturer</u>	<u>Part Number</u>	<u>Size</u>
American Midwest Power	CTS4-4L	400 amp
	CT46-4L	400/600 amp
	SCC8-4ACT	800 amp
	SCC12-4ACT	1200 amp
	SCC16-4ACT	1600 amp
	SCC20-4ACT	2000 amp
	SCC25-4ACT	2500 amp
	SCC30-4ACT	3000 amp
	SCC40-4ACT	4000 amp
EMI, Inc	CTC-WP3800P	800 amp
	CTC-WP1000P	1000 amp
	CTC-WP1200P	1200 amp
	CTC-WP1600P	1600 amp
	CTC-WP2000P	2000 amp
	CTC-WP2500P	2500 amp
	CTC-WP3000P	3000 amp
	CTC-WP4000P	4000 amp